

WIREMOLD



RC7FF Poke-Thru Series INSTALLATION INSTRUCTIONS

Installation Instruction No.: 1 002 349 R1 – Updated April 2005

Wiremold Electrical Systems conform to and should be installed and properly grounded in compliance with requirements of the current National Electrical Code, Canadian Electrical Code or codes administered by local authorities.

All electrical products may represent possible shock or fire hazard if improperly installed or used. Wiremold electrical products are UL Listed to U.S. and Canadian safety standards, made for interior use only, and should be installed in conformance with current local and/or the National Electrical Code.

IMPORTANT – PLEASE READ ALL INSTRUCTIONS BEFORE BEGINNING.

Products Covered: RC7CFFTC and RC7AFFTC
RC7AFFTC-LJB

CAUTION: Do Not operate tile stripper or resurfacing equipment over top of covers.
This may result in damage to the surface finish of the product.

Suitable for use in air handling spaces in accordance with Sec. 300-22 (C) of the National Electrical Code.

Step 1. Layout and locate position of hole(s).

CAUTION: Holes shall be spaced a minimum of 2' [610mm] on center and not more than one hole per each 65 sq. ft. [6 sq. m] of floor area in each span.

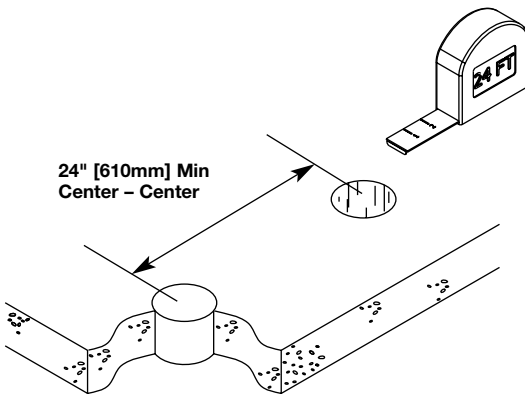

NOTE: Be certain to drill hole at least 4" [102mm] from any wall or pillar to leave enough room for poke-thru cover assembly.

Step 2. Remove 6 1/2" [165mm] section from carpet or tile. Use template provided.

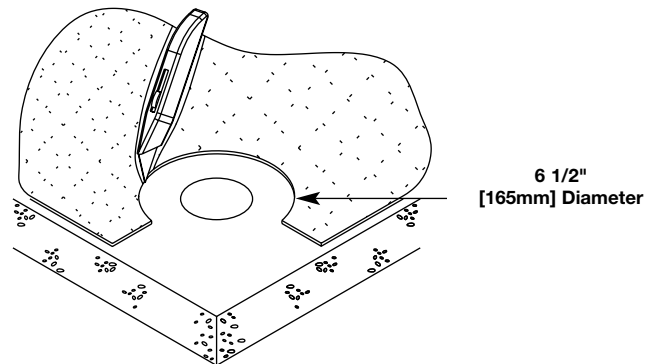

NOTE: For tile thickness greater than 3/4" [19.1mm] consult factory.

Step 3. Core drill hole.

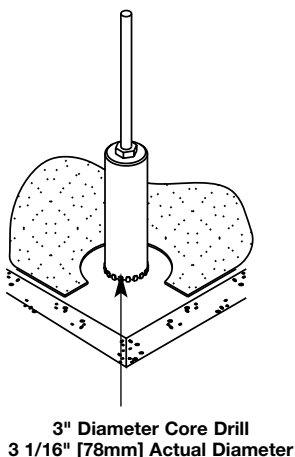

Step 4. Insert stem or assembly into hole.

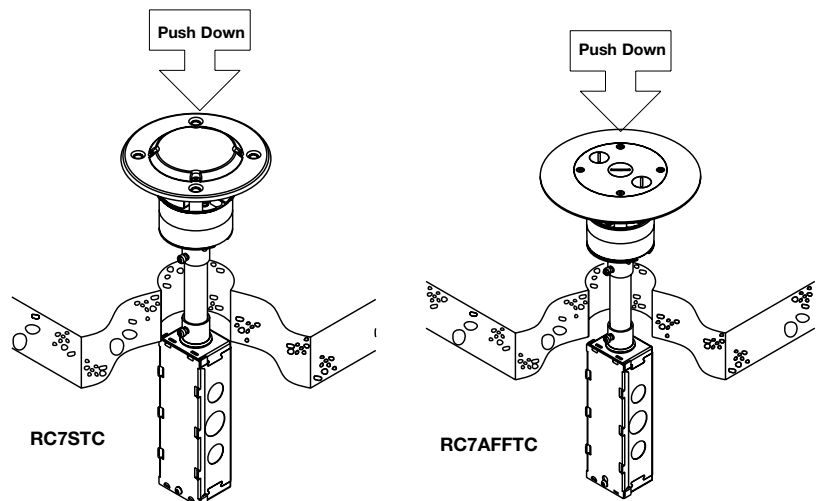

CAUTION: Poke-thru cannot be rotated in hole after insertion into floor.

Step 5. (If Applicable)

If stem is already installed, remove disposable plate. Place intumescent inserts into receptacle barrier. Install carpet/tile trim flange onto stem with four #6-32 screws provided.

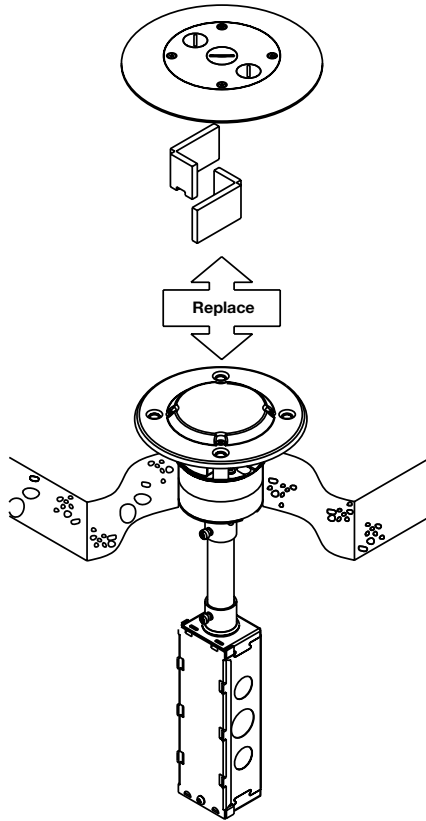

Step 6. (If Applicable)

If retro-fitting an existing stem (RC7S) or assembly (RC7AFF), remove cover assembly. Replace old receptacle shell, intumescent inserts and screws with the ones that are provided. Attach new cover assembly with four #6-32 screws provided.

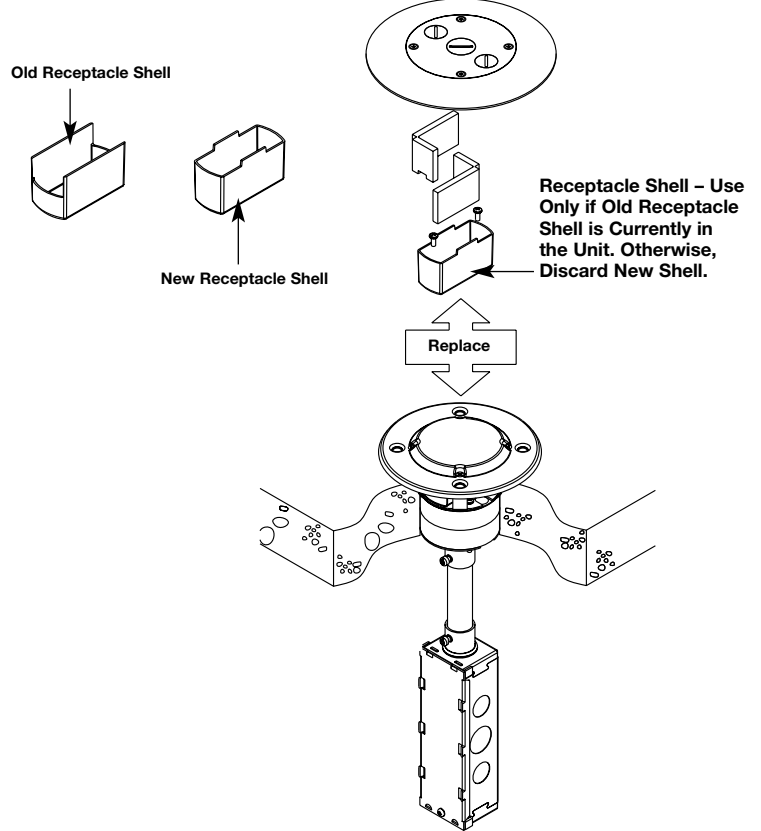

**RC7AFFTC Poke-Thru Less Junction Box
Cat. No. RC7AFFTC-LJB**

(Applies to installations in the City of Chicago or other locations where local codes require the use of a communication adapter, EMT compression fittings, and a junction box suitable for use in environmental air spaces.)

Step 7. Follow steps one thru four for installation.

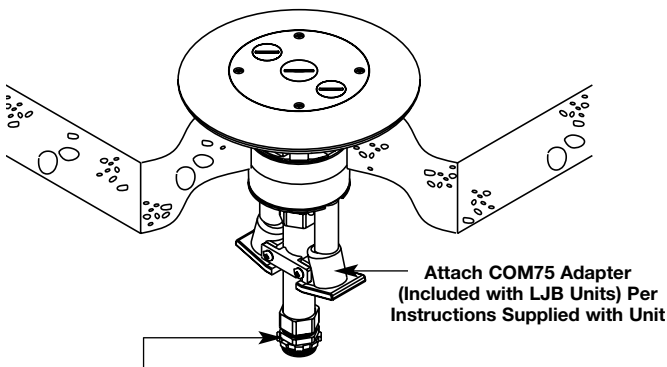

Once Poke-Thru is Pushed into the Cored Hole, from Below, Install a EMT Compression Fitting (Not Supplied) and Junction Box (Not Supplied) to the Conduit System. Complete Installation Per NEC and Local Codes.

Step 8. With assembly installed remove screw plugs and install conduit adapters as necessary.

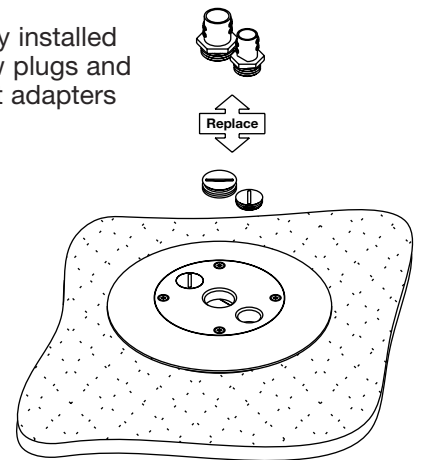

Step 9. Completed assembly.

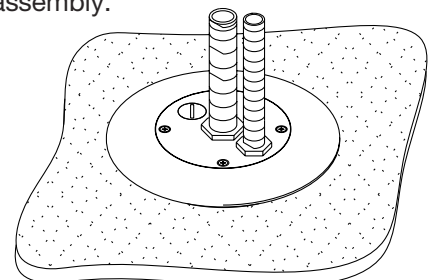

The RC7FFTC Series Poke-Thru Device is UL Listed and Classified to U.S. and Canadian safety standards to the following conditions:

The RC7STC Poke-Thru Stem with the RC7CFFTC Service Head Fitting, and the RC7AFFTC factory assembled poke-thru device, are for use with 1-, 1 1/2-, or 2-hour rated unprotected reinforced concrete floors and 1-, 1 1/2-, or 2-hour rated floors employing unprotected steel floor units and concrete topping (D900 Series Designs), or concrete floors with suspended ceilings. (Fire resistive designs with suspended ceilings should have provisions for accessibility in the ceiling area below the poke-thru fittings).

The assembled poke-thru stem and service fitting will not reduce the ratings of the floor assembly when the thickness and type of concrete (required for the specific rating) are within the specified limits and the fittings are installed as specified:

1. **Spacing** – Minimum of 2' [610mm] OC and not more than one unit per 65 sq. ft. [6 sq. m] of floor area in each span.
2. **Concrete** – Minimum thickness of structural concrete topping of 2 1/4" [57mm] over metal deck or a minimum 3" [76mm] thick reinforced concrete slab. Unit weight of concrete to be 110 to 155 pcf.
3. **Installation** – Mounted in a 3" diameter core-drilled hole in concrete per installation instructions accompanying the fittings or abandonment fittings. For use with power circuits, data and/or maximum 25-pair size telephone cables as tabulated below:

POKE-THRU FITTING TYPE	SERVICE FITTING TYPE	POWER CONDUCTORS (A)	COMMUNICATION CONDUCTORS (B)
RC7AFFTC	-	7 + 2 (.05214 sq in.) [33.641mm ²]	100 (.05000 sq. in.) [32.260mm ²]
RC7STC	RC7CFFTC	7 + 2 (.05214 sq in.) [33.641mm ²]	100 (.05000 sq. in.) [32.260mm ²]

The "TC" suffix letters indicate that device may be installed on tile or carpet covered concrete floors. The "LJB" suffix letters indicate units supplied without a junction box.

- (A) Maximum number of No. 12 AWG Type THHN conductors plus maximum number of No. 10 AWG type THHN conductors in power compartment of poke-thru fitting.
- (B) Maximum number of 22 AWG conductors in low voltage compartment of poke-thru fitting (4-pair cables have (8) conductors, 25-pair cables have (50) conductors). When conductors larger than No. 22 AWG are used, the aggregate cross-sectional area of the copper conductors shall not exceed the aggregate cross-sectional area of the 22 AWG conductors permitted in the low voltage compartment.

Copper Cross Sectional Area of Commonly Used Conductors	
Size	Solid
#24	.00032 sq. in. [.20645mm ²]
#22	.00050 sq. in. [.32258mm ²]
#14	.00323 sq. in. [2.08386mm ²]
#12	.00512 sq. in. [3.30321mm ²]
#10	.00815 sq. in. [5.25805mm ²]
# 8	.01296 sq. in. [8.36127mm ²]

NOTE: Use above values for solid or stranded conductors.

For use on carpet covered and tile floors up to 3/4" [19.1mm] thick.

Carpet Cutout Template

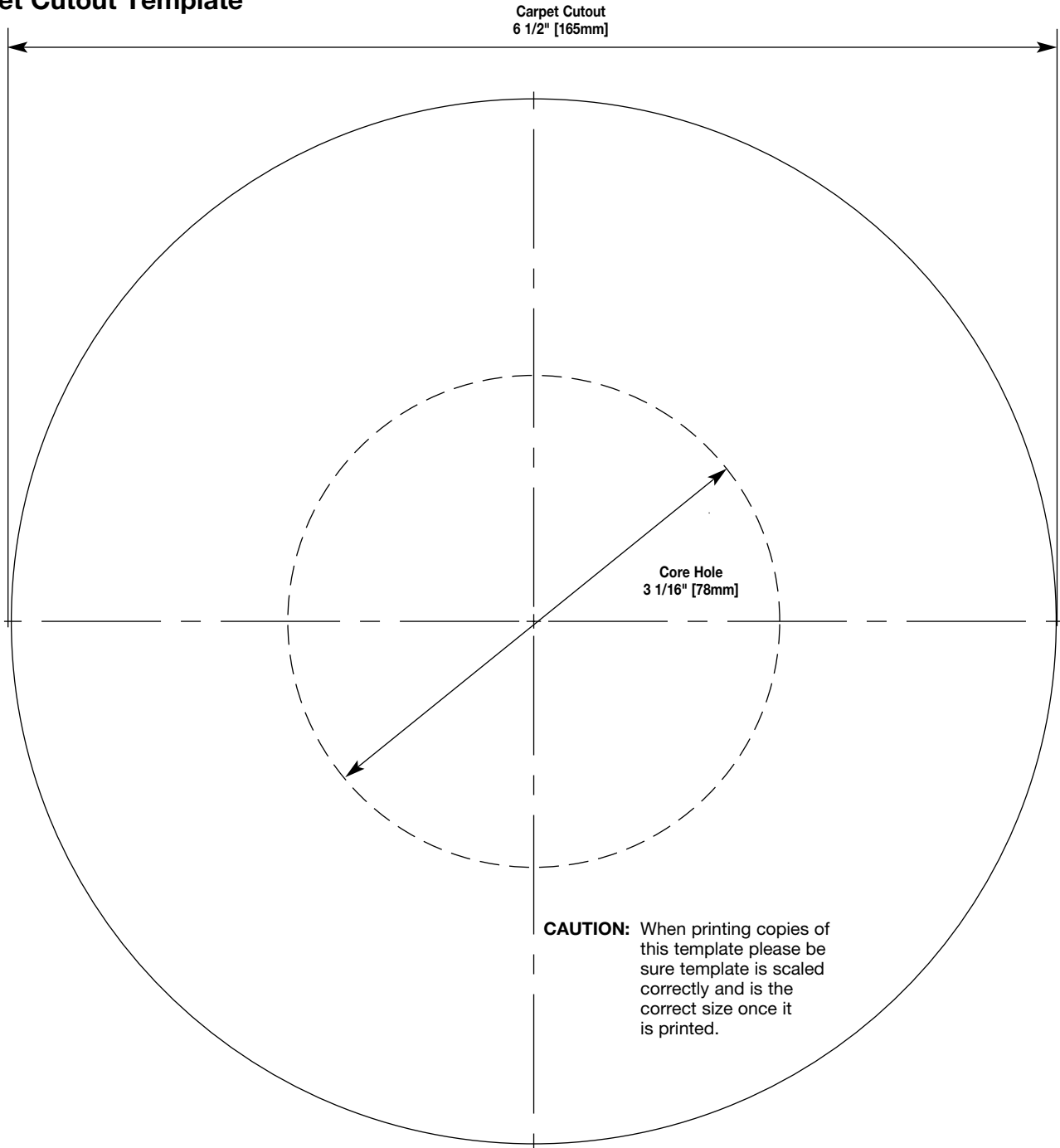

WIREMOLD



Wiremold / Legrand

U.S. and International:

60 Woodlawn Street • West Hartford, CT 06110

1-800-621-0049 • FAX 860-232-2062 • Outside U.S. 860-233-6251

Canada:

570 Applewood Crescent • Vaughan, Ontario L4K 4B4

1-800-723-5175 • FAX 905-738-9721

